

**VELOCIFERO**

**MOBSTER**

125cc-180cc



**MANUAL**

**VELOCIFERO.EU**

## TO OUR CUSTOMERS

Thank you for purchasing this, Scooter!

You are welcome to join our users. We have a range of products that are pleasing to the eye, such as utility vehicles and recreational vehicles.

o All-terrain vehicle (ATV) o multi-purpose vehicle

o Two-wheeled motorcycles or scooters

please read this manual carefully before driving; after reading this manual, you will have a more comprehensive understanding of the characteristics of this product and how to drive. For your convenience, please keep this manual on your car. This manual contains important safety information, it provides some special tips and necessary skills for driving the car, and it also contains basic maintenance and inspection procedures. If you have any questions about driving and maintaining your car, please consult your dealer.

Before each drive, do some check-ups, and at the same time, do regular maintenance, are some of the most basic driving common sense. This manual should be treated as a permanent part of the motorcycle, and even if the vehicle is transferred to another person, it should be handed over with the vehicle to the new owner.

The final interpretation right of this instruction manual belongs to Taizhou velocifero vehicle Co., Ltd.

Important note:

The following warning symbols appear in several places in this manual. In order to use the vehicle safely, follow the safety instructions that appear. please read this manual carefully, safety tips will be highlighted and appear in key locations.



Dangerous

Tip: If no action is taken, the operator or nearby personnel may die.



Dangerous

Tip: If no action is taken, there is a risk of operator injury or damage to parts.



warning

caution is required to avoid damage to the part.

Note:

prompts to make the process simpler or clearer information. No symbols are used.

# CONTENT

<b>Before driving</b> .....	1
General information .....	2
Serial number .....	3
Frame number .....	3
Engine No .....	3
<b>Parameter</b> .....	3
<b>Vehicle view</b> .....	4
Rear left view .....	4
front right view .....	5
Front Right view .....	5
<b>Operating part</b> .....	6
Brake handle .....	11
Left-hand handle switch .....	11
Right-hand handle switch .....	13
Throttle handlebar .....	14
Locks .....	14
Side brace .....	14
Passenger armrests and footrests .....	17
Vehicle-mounted tool .....	20
<b>Gauge</b> .....	22
Gauge indicator .....	23
Gauge display area .....	28
<b>Fuel system</b> .....	错误! 未定义书签。
Fuel tank .....	30
Fuel requirement .....	32
Octane rating .....	35
<b>Engine assembly</b> .....	38
Oil level check .....	41
Change the oil and filter .....	41
Engine oil capacity .....	50
Spark plug .....	32
Idle speed .....	35
<b>Intake and exhaust system</b> .....	38
Emission oil and gas monitoring system .....	41
Intake valve .....	50
Valve clearance .....	错误! 未定义书签。
Air filter .....	30
Throttle body .....	32
<b>Tire</b> .....	35
Tire size .....	38
Tire load .....	41
Tire wear .....	50

# CONTENT

<b>Braking system</b> .....	2
Front brake lever check .....	2
Rear brake pedal check .....	3
Brake oil level check .....	4
Brake fluid replenishment .....	5
Brake disc check .....	7
Brake caliper check .....	7
<b>Shock absorber</b> .....	8
Shock absorber check .....	8
Rear shock adjustment .....	9
<b>Electrical and optical signals</b> .....	9
Accumulator .....	11
Light .....	11
Fuse .....	13
Catalytic converter .....	14
<b>Fuel evaporation system</b> .....	14
<b>How to drive this car</b> .....	14
<b>Start vehicle</b> .....	17
Vehicle starting .....	20
Shift, drive .....	22
Braking .....	23
Parked .....	28
<b>Safe driving</b> .....	2
Safe driving tips .....	2
Routine security checks .....	3
Special precautions for high-speed driving .....	4
<b>Run-in period</b> .....	5
<b>Service interval</b> .....	7
Maintenance table during the break-in period .....	7
Maintenance table after the break-in period .....	8
<b>Common Motorcycle Faults and Causes</b> .....	8
<b>Vehicle Cleaning &amp; Storage</b> .....	9
General precautions .....	9
Car Wash .....	11
Decorative surfaces .....	11
Windshields and other plastic parts .....	错误! 未定义书签。
Chrome and aluminium .....	30
Preparation before storage .....	32
Remove vehicle from storage .....	35
<b>Intelligent connected vehicle terminal</b> .....	38

## Before driving

### warning

There are different warning stickers in the visible position of the vehicle, please do not remove any warning stickers. Without these stickers, you or others may not be able to recognize the hazard and result in injury.

### Dangerous

This product is only suitable for reasonable and prudent driving with a trained person holding an appropriate driver's license in road traffic. Note the following:

Before driving, the user should check each part of the vehicle according to the daily safety inspection chapter, and if any problems are found, repair them before driving. users shall comply with local laws and regulations.

It is forbidden to drive a vehicle under the influence of alcohol or drugs.

please wear appropriate protective gear such as helmets, boots, gloves, and protective pants or jackets during all driving.



### Dangerous

Please do not make any modifications to the vehicle, non-standard modification behavior may lead to serious consequences.

Modification of the device or electrical components of this product will affect noise, emissions and vehicle performance.

Incorrect loading behavior can lead to serious consequences. unsuitable mounting accessories can cause safety hazards.

Always use genuine VELOCIFERO Parts and our approved accessories. The use of non-VELOCIFERO Components, improper installation of accessories or improper loading will affect the performance of the vehicle and even violate regulatory requirements. Please note that you are responsible for your own safety and the safety of others.

 warning

The components and accessories that are equipped with this car have been specially verified, so we strongly recommend that you use original VELOCIFERO Parts and install our approved accessories.

 warning

changes in the overall weight of a vehicle have a significant impact on the dynamic performance of the vehicle, so you must accept our regulations on the weight of the load, the number of passengers on board and the installation of accessories.

### General information

Here are some basic things you should be aware of before driving

1. Any occupant must be very familiar with the particularity of motorcycle driving , if the position of the occupant seat is not suitable , the center of gravity of the human body deviates too much from the center plane of the motorcycle or the sudden movement in the driving may affect the manipulation , control of the motorcycle; the occupant tries to keep sitting on the passenger seat as smoothly as possible , and cannot affect the driver's control; cannot carry animals on the motorcycle.
2. To reduce the impact on the center of gravity of the motorcycle, all luggage carried on the motorcycle must be as low as possible, the weight of the luggage must be evenly distributed on both sides of the motorcycle, and the luggage should not protrude too long from the back of the motorcycle.
3. Baggage must be securely fastened to the motorcycle, make sure that the baggage cannot be moved before driving, and when the motorcycle feels unstable while driving, the baggage should be rechecked for security and readjusted if necessary.
4. Do not carry overweight or oversized baggage. overloading inevitably affects handling and dynamics.
5. Do not install accessories that reduce the performance of the motorcycle and carry luggage that reduces the performance of the motorcycle, and make sure that nothing you do will affect any lighting system, ground clearance, braking performance, roll angle, handling performance, tire compression stroke, fork working stroke or other related driving performance of the motorcycle.
6. Increased weight on the handlebars or forks will affect steering performance and cause unsafe driving factors.
7. The shroud, windshield, backrest and other large components will affect the stability and handling of the motorcycle; not only will they increase the weight but also reduce the area of the motorcycle when driving. Due to the lack of design verification, it can be unsafe after installation.

8. This car cannot be converted into a side three-wheeled motorcycle, cannot be used to tow a trailer or other vehicles, if the user of the car is caused by the damage or injury caused by the modification of the car, we will not be responsible.

Maximum load capacity: 150 kg (driver, luggage and accessories).

serial number

Please record the vehicle's serial number at the location indicated in the figure below.

Frame number

Engine number

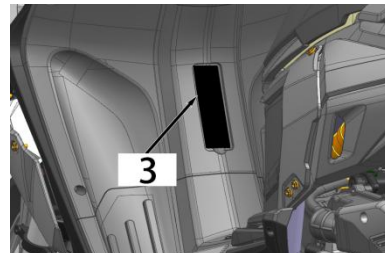
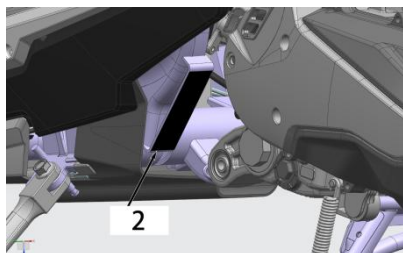
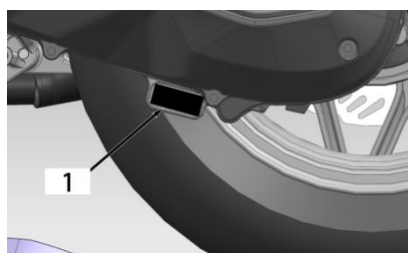

1. Engine number	2. vehicle nameplate	3. Frame number
------------------	----------------------	-----------------

parameter

MOOBSTER 125	
performance	
Maximum net power	8.9 Kw / 8250 rpm
Maximum torque	11.7 N.m   6500 rpm
Size	
Length	1873 mm
Full width	746 mm
Full height	1120 mm
Wheelbase	1341 mm
Seat height	797 mm
Ground clearance	155 mm
Curb weight of the whole vehicle	122 kg
Motor	
Version	Single-cylinder, four-stroke, water-cooled, horizontal
Displacement	124.8mL
Bore x stroke	52.4 mm x 54.9 mm
Compression ratio	12 : 1
Starting system	Electric start
Fuel supply method	ignition fuel injection

Ignition control method	ECU ignition	
Lubrication system	Pressure splash lubrication	
Oil type	SAE10W/40 SJ Grade JASOMA2 certified motor oil	
Transmission		
Variable	Infinitely variable speed international standard gear	
Drive	Gear driven	
Chassis		
Tire specifications	Front	120/70-12
	Rear	130/70-12
Rim specifications	Front	MT12*3.0
	Rear	MT12*3.0
Fuel tank capacity	7,7 litri	
Electrical installations		
Accumulator	12V/7 Ah	
Headlamps	LED	
Tail light / brake light	LED	

## Vehicle view

### Rear left view

1: Appearance

2: Rear brake handle 3: switch on the left hand

4: Electric door lock/-

seat cushion lock/faucet lock

5: Right-hand handle switch

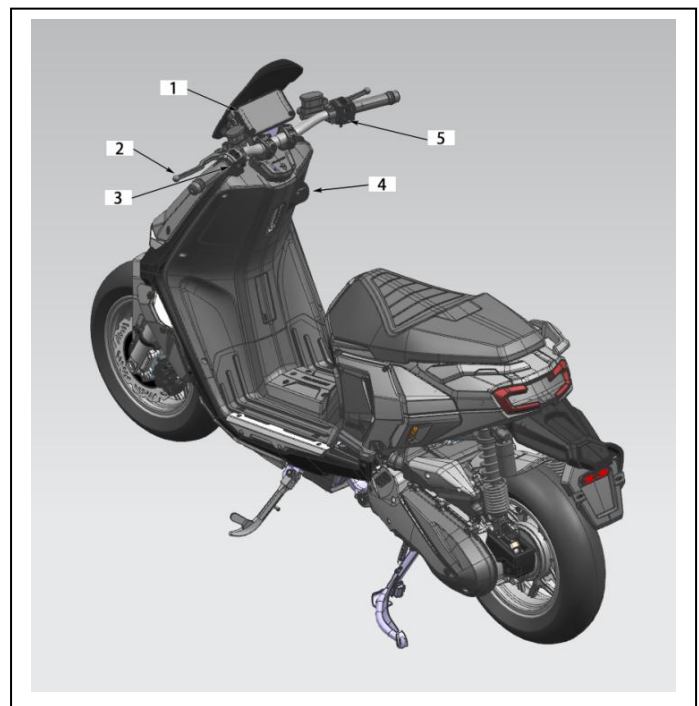

## Front Right view

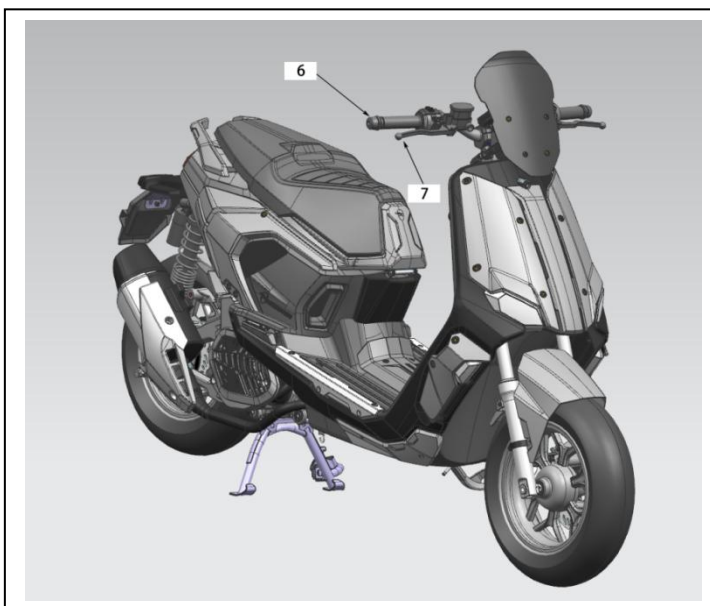

6: Throttle handlebar

7: Front brake handle

## operating parts

### Brake handle



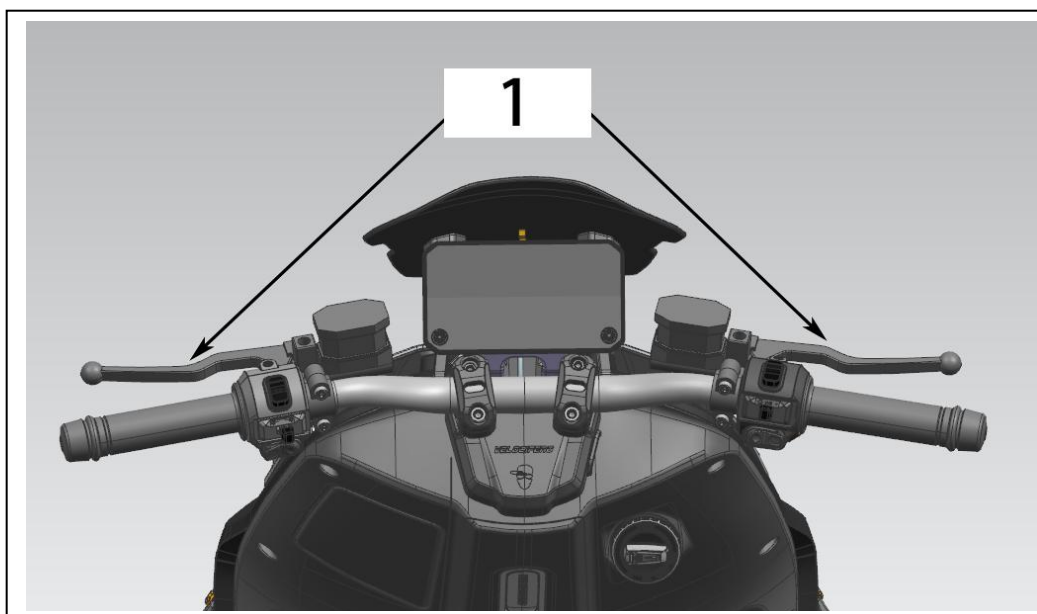

Brake lever 1 is located on the left and right sides of the steering handle, and the brake lever is used to perform the front and rear brake caliper braking action.

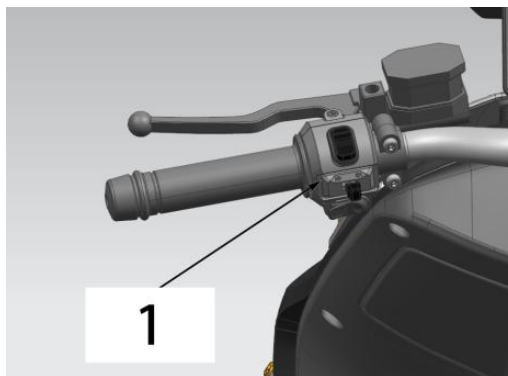

## Switch on

Left hand handlebar switch 1 is located on the left side of the handlebar  
Left handle switch function



2	Brightness adjustment button		Adjust to this position so that it is the high beam
			Adjust this position to a low beam
3	Steering Quadrant		Adjust to this position and the right turn signal is on
			Adjust to this position and the left turn signal is on
4	Horn button		The horn sounded with a short press of the button
5	Overtaking paddles		Press to turn on the high beam and release the auto rebound Turn off the high beams

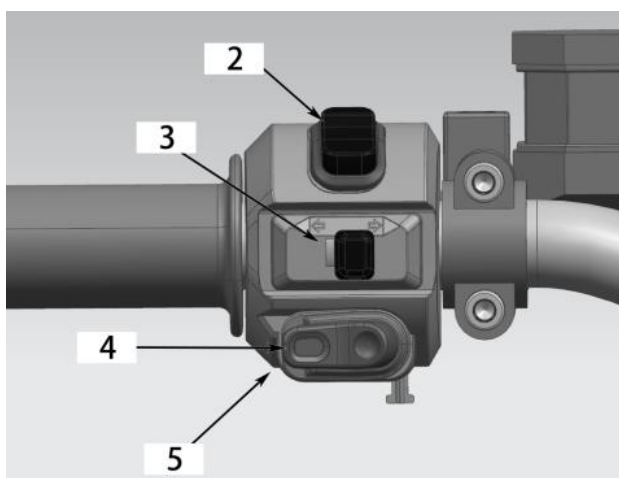

Right-hand

The right handle switch 1 is Right-hand

2	start button	——	short press this position to start the vehicle
3	Illuminated buttons	——	when switching to this position, the headlights, position lights, taillights, etc. can be lit
		——	when switching to this position, position lights, taillights, etc. can be lit
		●	when switching to this position, the headlights, position lights, taillights, etc. are turned off

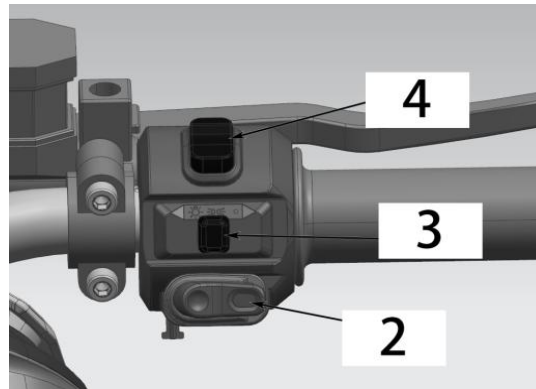
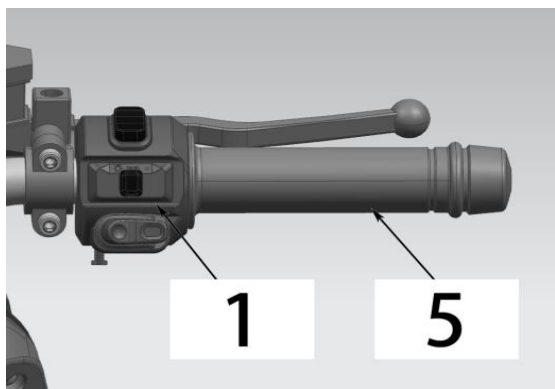

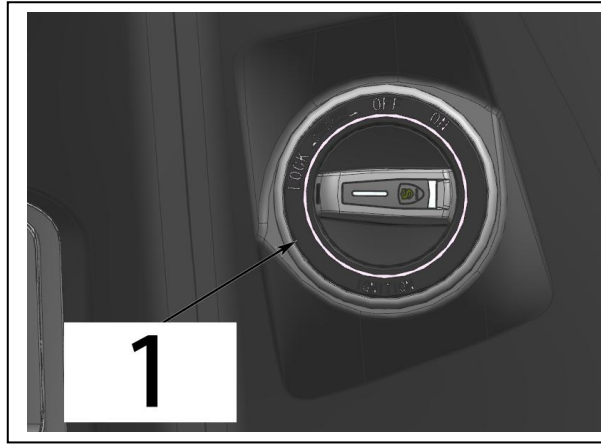

Throttle handlebar

No.4 is the throttle handlebar which is located on the right side of the handlebar



Locks

Ignition switch lock 1

Direction handle locks		when the steering knob is turned to the far left, press the key to adjust to this position and lock the steering knob
shut down		when the key is adjusted to this position, the engine does not work, and all circuits of the vehicle is disconnected
Initiate		When the key is adjusted to this position, the engine can work, and all circuits of the vehicle are switched on

### seat cushion lock 1

The seat cushion lock is located on the right side of the vehicle.  
To open the saddle, you need to open the saddle lock.

### Fuel tank cap

Before opening the tank, you must: The vehicle has stopped.

The engine is turned off.

Insert the key and unlock the seat cushion lock.

Flip opens the cushion; open the fuel tank cap.

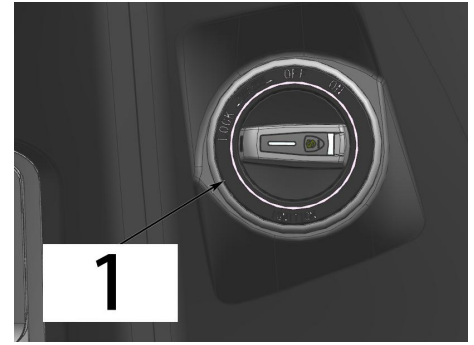

### side stand 1

The side stand is located on the left side of the vehicle and is used for parking the vehicle; when the side stand is opened, the engine is switched off and it is not possible to start it.

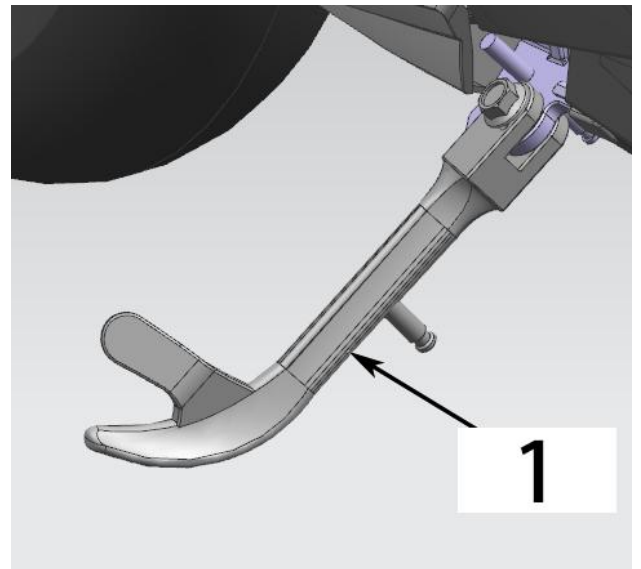

Passenger armrests and footrests  
passenger armrest 1 is a device that is fixed on a motorcycle and can be held by an occupant

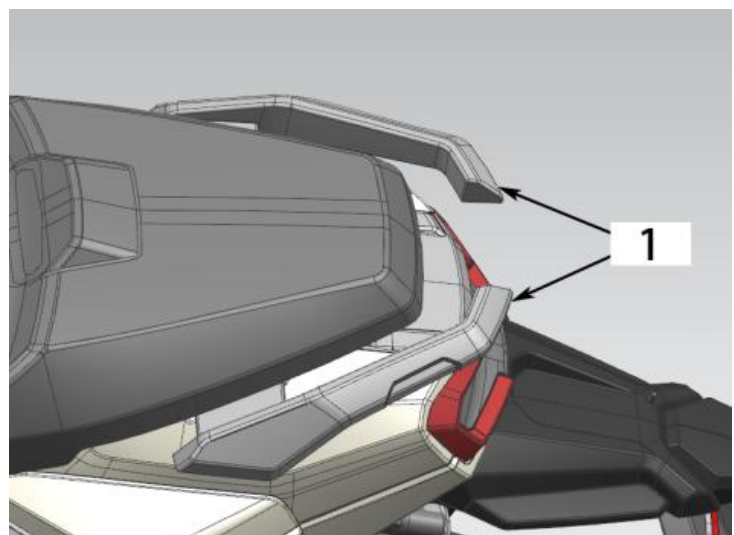

The pedal device 2 is a pedal or pedal device that is fixed on the motorcycle and can be stepped on by the driver and passengers.

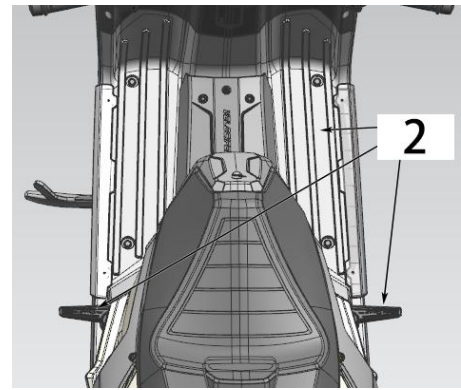

### On-board tools

The vehicle-mounted tool is generally located under the seat cushion, and the vehicle-mounted.

speedometer

Gauge indicator

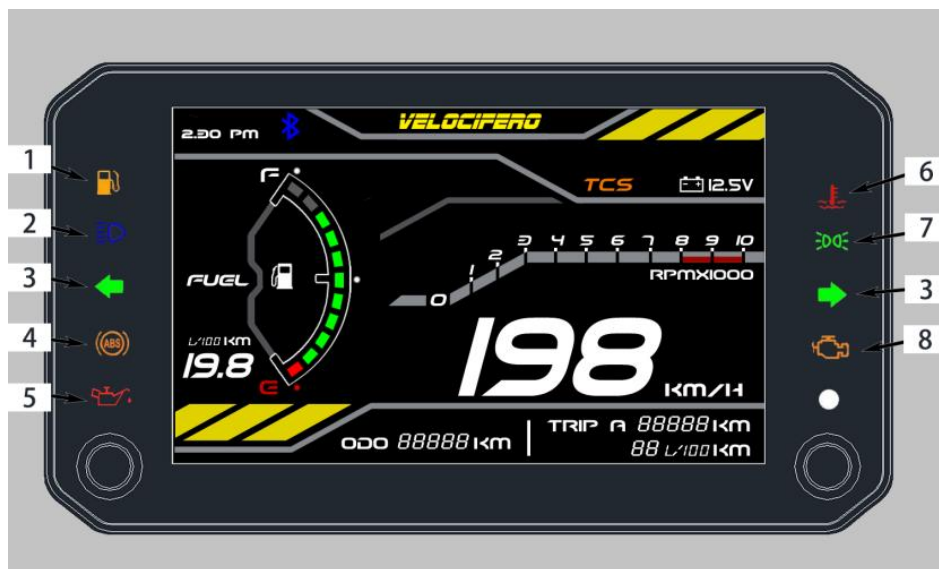



1	Fuel alarm indicator light	4	ABS indicator light	7	position light indication
2	High beam indicator light	5	voltage indicator light	8	Fault indicator
3	Turn signal indicator	6	water temperature alarm indicator light		

### Fuel Alarm Indicator - 1

When the fuel is low, the fuel alarm indicator flashes. High beam indicator - 2

When the light switch is set in the — position and the dimmer switch is set in the  position, the indicator light is always on.

### Turn indicator - 3

When the turn switch is set in the  position, the left turn indicator flashes. When the turn switch is set in the  " position, the right turn indicator flashes. ABS indicator light - 4

When the ABS System fails, the ABS indicator light is on. voltage indicator - 5

When the battery voltage is lower than 12v, the voltage indicator flashes. water temperature alarm indicator - 6

When the engine water temperature is too high, the indicator light is always on. position light indication - 7

When the lighting button is set in the „ g " position, the position light indicator light is on. Fault Indicator - 8

When a fault is detected in the vehicle circuit, the fault indicator lights are always on.

## Fuel system

### Fuel tanks

When adding fuel to the fuel tank, try to avoid the fuel flowing out of the fuel tank and dispose of the outflow of fuel to prevent contamination and danger caused by the fuel.

Fuel tank volume: 6 L



### Dangerous

Fuel is flammable, please refuel in a ventilated place, turn off the engine in advance and wait for the engine and muffler to cool down thoroughly. Smoking or other pyrotechnic activities in the refueling area or fuel storage area are strictly prohibited. Do not overfill the fuel to avoid spilled fuel from flowing to hot parts, and do not exceed the maximum fuel level when filling the fuel, as the temperature rises, the fuel will expand due to heat and may spill and damage vehicle parts.

Fuel is toxic and harmful to health. Do not allow fuel to come into contact with skin, eyes, and clothing. Do not inhale fuel vapors.

When fuel comes into contact with the skin, rinse the contact area immediately with plenty of water.

If fuel comes into contact with eyes, wash it immediately with water and seek medical attention.

When fuel comes into contact with clothing, change clothing in a timely manner. If you swallow fuel, seek medical attention immediately.

After repairing or disassembling fuel system parts, contact the dealer for a thorough inspection to avoid other hazards such as fuel leakage.

proper disposal of fuel to avoid environmental hazards.

## Fuel requirements

This vehicle is suitable for unleaded petrol gauge 92 (v) or above.



### warning

Do not use leaded gasoline, using leaded gasoline will destroy the catalytic converter. (For further understanding, please refer to the relevant catalytic converter information) Be sure to use fresh gasoline. Gasoline oxidizes leading to loss of octane, volatile compounds, producing gelatinous and lacquer-like deposits that can damage the fuel system.

## octane rating

The higher the octane rating of gasoline, the greater its ability to suppress engine knocking or cylinder knocking and is often used to describe the octane number. Make sure to use unleaded gasoline with an octane rating of 92 (V) or higher.

 warning

If the engine is knocking or knocking, use high-quality or higher-octane unleaded gasoline.

### Engine assembly

In order to ensure the normal operation of the engine, transmission mechanism and clutch and other moving parts, it is necessary to ensure that the oil level in the engine is between the upper and lower scale marks of the oil dipstick, and check and replace them according to the regular maintenance chart. The long-term lubrication process not only generates dirt and metal impurities, but also consumes itself.

 Dangerous

If the vehicle is driven under the condition of insufficient engine oil, poor oil quality, and too dirty engine oil, it will accelerate the wear and tear of the engine and can cause sintering of the engine or transmission mechanism, accidents and personal injury.

Make sure the vehicle is turned off.

use side supports to prop up the vehicle on level ground.

If the vehicle has just been used, wait a few minutes until the oil has settled completely.

Righting the vehicle and checking the engine oil level through the oil ruler 1;

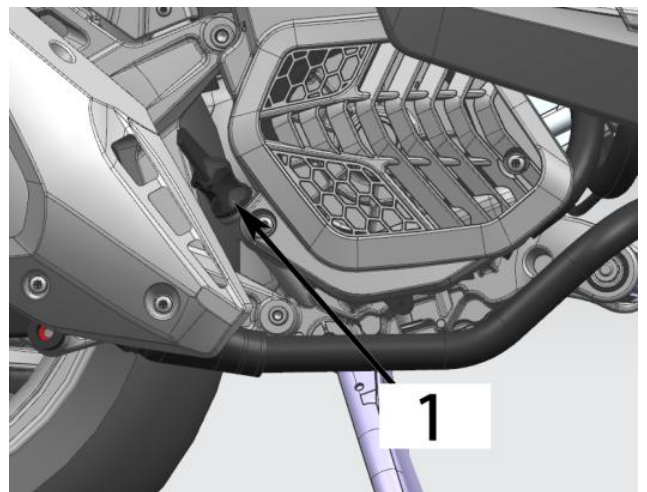

Replace engine oil and engine

use side supports to prop up the vehicle on level ground.

 dangerous

Warming up the engine for too long will cause the engine and oil temperature to be too high. Please wear appropriate protective clothing and protective gloves when working. In case of burns, use running cold water to rinse the wound for more than 10 minutes until the wound no longer hurts and seek medical attention promptly.

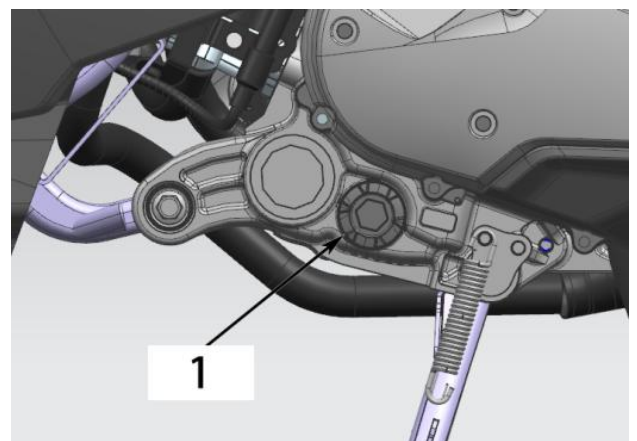

place an oil basin under the oil drain position; Remove the magnetic drain bolt and washer 1;

Drain the used engine oil.

 warning

Motor oil is a toxic substance, please dispose of it properly after use.

Remove the oil filter cover and replace it with a new one; reinstall the oil filter;

 warning

When installing the oil filter, an oil film should be applied to the filter seal.

clean the vicinity of the oil drain bolt and the oil drain port.

Reinstall the oil drain bolts and washers after replacing the new washers; Tightening torque: 25N - m.

Remove the filler plug 2;

Add 800ml of SAE10w/40 SJ grade JASOMA2 certified engine oil; reinstall the oil filler plug.

Tightening torque: 25 N - m

Idle the engine for a few minutes to fill the oil filter; Turn off the engine.

check the oil level and adjust based on the actual oil level.

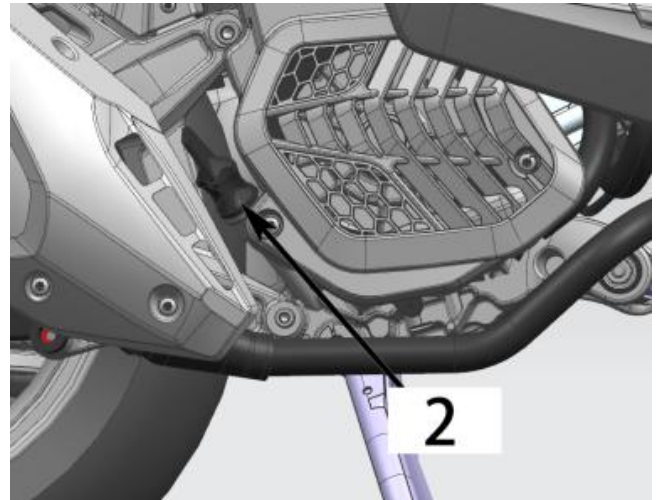

## Engine oil

when changing the oil filter: 0.8 L

We require the use of APISH and higher motor oils, with JASOMA2 certified motor oils preferred first and JASOMa certified motor oils secondary.

while 10w-40 is one of the most recommended oils for most ambient temperature conditions, the oil viscosity also needs to change when the ambient temperature conditions in the spark plug.

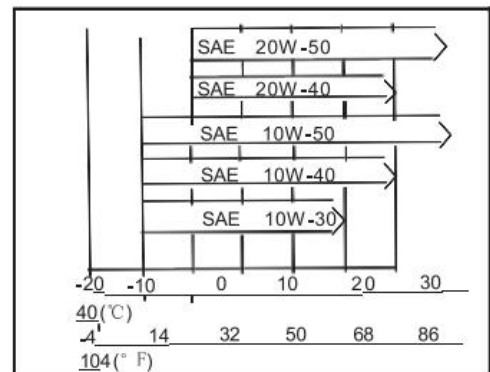

The standard replacement of the spark plug is specified in the regular maintenance chart. Disassembling the spark plug must be done by your dealer. \_\_\_\_\_

spark plug model: NGK CPR8EA-9

New spark plug gap 1: 0.8 mm ~ 0.9 mm

Tightening torque: 18 N-m



warning

Never adjust the electrodes gap. Replace the spark plug when the gap exceeds 1.0 mm

### Idle speed

The idle speed of the car has been adjusted when leaving the factory, and the user can not adjust the idle speed of the car, no

It will affect the performance of the whole vehicle. You must be contacted when it is necessary to replace a part that affects idling

of dealers replaced and recalibrated the ECU with a fault diagnosticator.



warning

Improper adjustment of the idle speed can lead to serious consequences.

idle speed: 1700 r/min  $\pm$  150 r/min

### Intake and exhaust systems

#### Emission oil and gas monitoring system

The exhaust oil and gas monitoring system are monitored by an oxygen sensor. An oxygen sensor is installed on the exhaust pipe, which monitors the degree to which the exhaust burns completely, and it converts the oxygen content in the monitored exhaust into an electrical signal that is transmitted to the ECU. When the ECU judges that the exhaust combustion is incomplete, the ECU re-determines the fuel injection amount of the injector according to the throttle opening signal provided by the throttle position sensor and the inlet air temperature signal provided by the intake temperature sensor,

So that the oil-gas mixing ratio can be effectively adjusted , and finally ensures the thorough combustion of oil and gas.

### Intake valves

The intake valve is a valve that controls the intake of air from the air filter and prevents the gas entering the cylinder from flowing back. check according to the provisions of the regular maintenance chart. when the engine is unstable, the engine power is reduced, or the engine is making abnormal noise, the intake valve can be checked.

The disassembly and inspection of the intake valve must be done by your dealer. valve clearance

valves and valve seats wear out during use and need to be adjusted after a period of use .

 warning

If the valve and valve seat tappet are worn out during use, the valve clearance is not adjusted, resulting in the valve closing is not tight or there is no clearance, or the engine performance is reduced, or the engine idle is abnormal and abnormal, and the engine can be seriously damaged. The clearance of each valve must be checked and adjusted according to the regular maintenance chart. The job of checking and adjusting the valve clearance must be done by your dealer.

### Air filter

A Clogged air filter will reduce the air intake to the engine, increase fuel concentration, reduce engine efficiency and cause spark plug drowning. The air filter element must be cleaned according to the regular maintenance chart. when driving in dusty, wet and muddy environment.

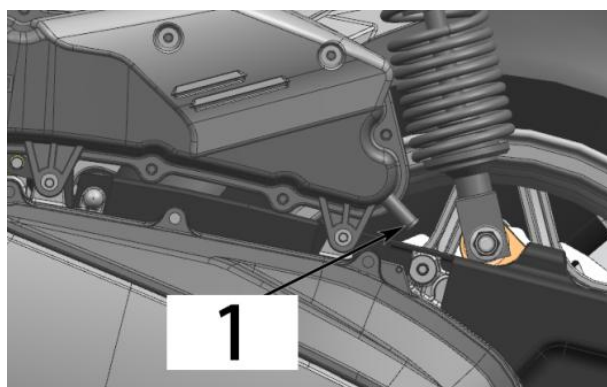

 warning

When engine oil sticks to surfaces such as tires and plastic parts, it can cause damage.

The engine inhaling unfiltered air can negatively affect its durability, and it is important not to run the vehicle without an air filter.

### Throttle body

The throttle limit screws on the throttle body are precisely set and cannot be adjusted. check whether the idle speed of the vehicle is stable, if the idle speed is unstable, please contact the professional service personnel of the company's designated maintenance unit to check and deal with it.

### Tire

This car only uses tubeless tires, rims and valves, must use the recommended tires, rims and valves, cannot be installed on tubeless rims with inner tubes, improper tire installation may cause air leakage, do not install tubes on tubeless tires.

## Tire specifications

Tire specifications	Front wheel	120/70-12
	Rear wheels	130/70-12
Tire pressure	Front wheel	200 kPa
	Rear wheels	220 kPa
Minimum depth of use on the surface of the tire	Front wheel	0.8 mm ~ 1 mm
	Rear wheels	0.8 mm ~ 1 mm

Improper tire pressure or exceeding the tire's load limit can affect handling and vehicle performance and cause loss of control. Use a tire pressure gauge to check your tire pressure regularly and make appropriate adjustments.

### warning

In order to guarantee the safety and stability of the operation, only the tires and air pressure that we recommend are used.

The front and rear wheels use tires from the same manufacturer with the same tread pattern.

The smooth surface of the new tire can cause loss of control and injury, and the whole part of the new tire is rubbed against the ground at different inclination angles in a moderate driving mode, and the tire surface can form a normal friction surface after a 160km run-in period. During the run-in period, avoid sudden, extremely sharp braking, extreme acceleration and sharp turns.

## Tire load

we recommend a maximum capacity of 150 kg, including the driver, luggage and accessories.

## Tire wear

When the tire face wears beyond the service limit, it will be punctured and malfunction. In general, 90% of tire failures occur during the last 10% of the tire's life, so continuing to use the tire surface when it is worn to a smooth surface will create an unsafe factor. According to the regular maintenance drawing, measure the specified depth of the tire surface, and replace the tire with a new one before it is worn to the minimum service limit. visually inspect the surface of the tire for cracks and cuts and replace the tire with a new one if it is seriously damaged. For example, a partial expansion of the tire indicates that the tire has been damaged. Remove sand and other foreign objects that have penetrated the tire surface.



## warning

When the outdoor ambient temperature is below - 10c, it is recommended to park the vehicle indoors if it needs to be parked for a long time.

When the bike has been parked outdoors and the ambient temperature was below 4 Celsius degrees, repeatedly operate on the throttle (full open/full closed) before starting the engine (engine must be off), to avoid throttle cable blockings due to icing.

In winter, when parking for a long time, avoid using side braces, and use middle supports or parking frames to park the car so that the tires are not subject to the gravity of the wheels. park your car in winter to avoid bogging your tires in ice/snow for a long time.

When parking for a long time in the field in winter, it is recommended to lay under the tires with materials that can keep warm, such as branches, wastepaper, and sand.

## Braking system

In order to ensure the performance of the vehicle and the safety of the individual, regularly inspect the vehicle braking system, and keep the braking system components in a good state. If there is any malfunction in the braking system, do not continue the ride and contact your dealer to have it serviced for you.

### Brake handle inspection

Use the side support to support the vehicle, gently pinch the left and right brake handles to check the free travel of the brake handle.

Free stroke: 10 mm  $\pm$  2 mm

check the front brake handle for cracks, abnormal noises, etc., and replace it with a new one if found.

 warning

If the brake handle feels soft during operation, the brake line may contain air or not enough brake fluid. In the event of such a dangerous condition, it is forbidden to drive the vehicle, and the brakes should be checked immediately by contacting a VELOCIFERO authorized after-sales service center.



## Brake oil level check

support the vehicle with middle support.

check the liquid level of the front and rear brake Cups.

If the level of the brake fluid is in zone A: drain excess brake fluid to zone B; If the level of the brake fluid is in zone B: the fluid level is appropriate.

If the brake fluid level is in zone C Or is not visible:

- Check the brake pads thickness and replace if necessary
- Check again the oil level and fill the same brake fluid to zone B.

 warning

If the brake fluid level is frequently located in the C Zone, the brake system may not be sealed or damaged, contact an authorized VELOCIFERO Service center immediately.

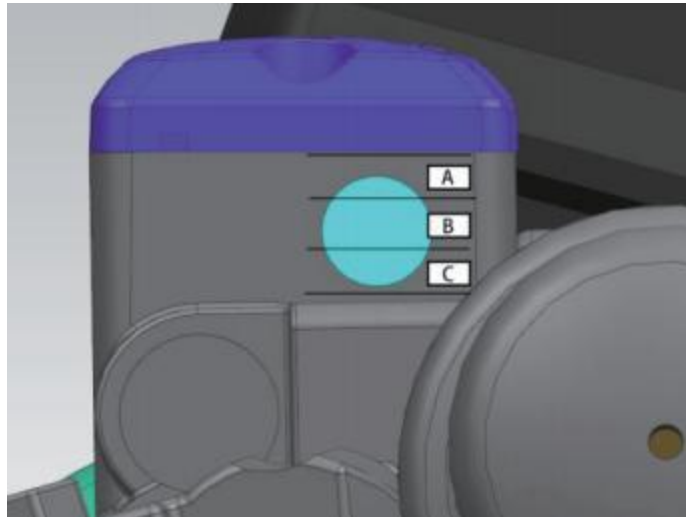

## Brake fluid replenishment

 dangerous

Brake fluid can irritate the skin.

Make sure the brake fluid is stored out of the reach of children.

Do not allow the brake fluid to come into contact with your skin, eyes, or clothing, and wear protective clothing and goggles when operating.

seek medical attention as soon as brake fluid is swallowed.

In case of contact with skin, rinse the contact area immediately with plenty of water.

As soon as the brake fluid comes into contact with the eye, rinse the eye immediately

and thoroughly with water and then seek medical attention. If

brake fluid spills on clothing, change it.

 warning

Brake fluid that has been used for too long will reduce the braking effect, So please replace the brake fluid according to the maintenance schedule. use only the DOT4 brake fluid model indicated on the Cup. Mixing different brands of brake fluid can cause damage to the brake system, it is recommended to always use genuine VELOCIFERO brake fluid. If you are unable to identify the brand of your original brake fluid, contact your dealer for a complete replacement.

Note:

After the brake fluid drops, it will cause negative pressure in the oil Cup, which may cause the oil coaster to dent, so it is necessary to remove the oil Cup cap and release the pressure, adjust the oil coaster and reinstall the oil coaster and the oil Cup cap.

Brake oil Cups Remove bolt 1;

Remove the cover plate and oil coaster 2; Replenish the brake fluid to the B area; Install the cover plate and oil coaster in place; Install the bolts.

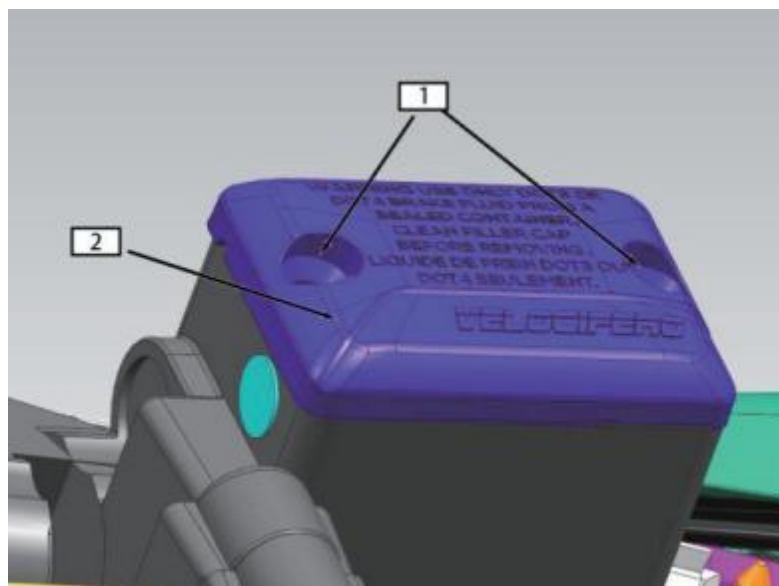

## Brake disc inspection

Inspect the brake disc regularly to see if the disc is damaged, deformed, cracked or worn, a damaged disc may cause the brake to fail, a worn disc will reduce the braking distance, if you find that the disc is damaged or exceeds the wear limit, contact your dealer immediately to replace the disc with a new one.

The thickness of the front and rear brake discs is detected at multiple positions on the brake discs.

wear limit: 3 mm

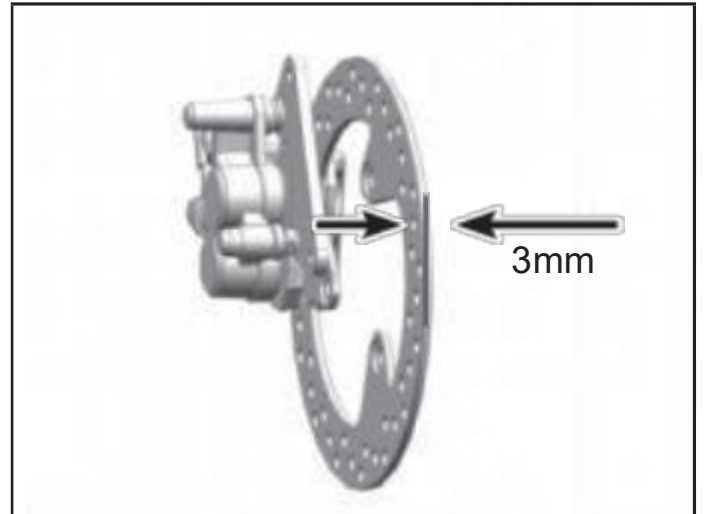

## Brake caliper check

check whether the brake caliper is abnormal before driving, check the minimum thickness of the brake pad regularly, the friction pad is too thin will cause the brake pad bracket to rub the brake disc, which will seriously reduce the braking effect and damage the friction pad. check the minimum thickness of the brake pads on all brake calipers.

Minimum friction plate thickness:  $\geq 1.5$  mm

If the thickness of the brake pads is less than the minimum thickness of the brake

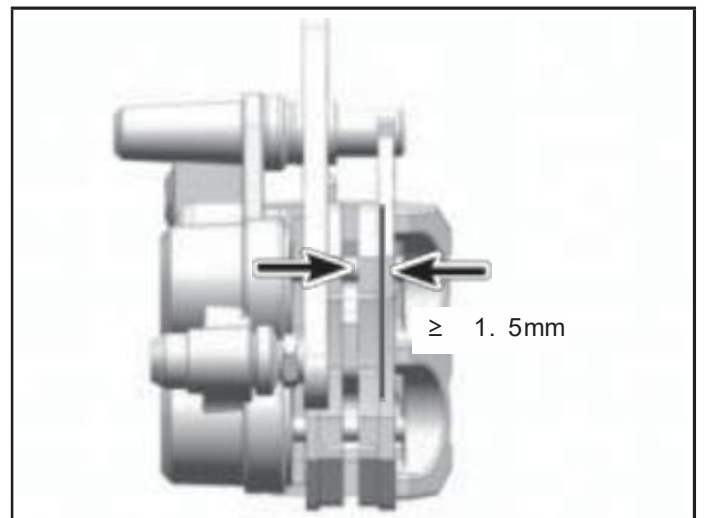

## Shock Absorber

shock absorber check

Hold the steering handlebar and compress the fork a few times to check if it works smoothly.

observe whether there is leakage of shock absorbing oil, whether there are scratches and friction noises on the working part of the fork tube;

check whether there is mud and sand on the fork pipe of the front shock absorber after driving, if there is mud and sand, it needs to be cleaned, otherwise it is easy to cause damage to the oil seal and oil leakage of shock absorption.

press the seat cushion a few times to check whether the shock absorber is working smoothly.

observe whether the rear shock absorbing leaks shock absorbing oil;

If you notice any problems with the shock absorber, you must contact your dealer. Rear shock adjustment

The rear shock absorbers are adjusted to their best condition when they leave the factory, making them suitable for most situations.

contact your dealer to adjust the spring preload, do not adjust it yourself.



**Dangerous**

This part contains high-pressure nitrogen, and an explosion may occur if it is operated incorrectly; Read the instructions.

Do not throw it into fire, open holes, or open it.

## Electrical and optical signals

### Lead Acid Battery

The car is equipped with a maintenance-free battery, so it is not necessary to check the amount of battery electrolyte or add distilled water. Once the electrolyte has been poured into the battery, the seal does not have to be removed. However, in order to have the best battery life, you must charge the battery properly to ensure that the power required for the starting motor is supplied. When the vehicle is in frequent use, the vehicle charging system automatically charges the battery. If the vehicle is used only occasionally or for a short period of time, the battery may be low. The battery will self-discharge, and the self-discharge rate will vary depending on the type of battery and the ambient temperature. When the ambient temperature increases, the discharge rate increases. For example, the self-discharge rate doubles for every 15°C increase in ambient temperature.

In very cold weather, improper charging of the battery, easy to cause electrolyte freezing, after freezing can cause the battery to rupture and deformation of the metal plate, fully charge the battery can improve the anti-freezing ability.

### Battery sulfation

A common battery failure is sulfation. When the battery loses power for a long time, the electrolyte can be sulfated. sulfation is an abnormal product of chemical reaction inside the battery. If the battery continues to be discharged when sulfation occurs, the battery plates will cause permanent damage, and the battery will not be charged. When the battery has such a failure, it can only be replaced with a new one.

### Battery maintenance

The user must ensure that the battery is fully charged, otherwise the battery will be damaged.

If you don't drive much in your car, you must check the battery voltage with a voltmeter every week. If the voltage of the battery is lower than 12.8 V, the battery must be charged with a charger (contact your dealer for checks). If you do not use the vehicle for more than two weeks, you must use a charger to charge the battery. Do not use an automatic fast charger to charge the battery, as this may overload the battery and damage the battery.

### charger

For detailed instructions on chargers, contact your dealer.

## Battery charging

Remove the battery from the car: first to remove is NEGATIVE (Black) Pole.

Connect the charger wire and ensure that the charging current is  $1/10A$  Of the battery's capacity, for example, if you charge a battery with a capacity of 10 Ah, its charging current is 1 amp.

When you put the battery back in the car, make sure the battery is fully charged. First to connect is the POSITIVE pole (RED)



warning

It is forbidden to disassemble the battery seal, otherwise it will damage the battery. Do not install ordinary batteries in this car, otherwise it can cause the electrical system to work abnormally.

When removing the battery, the negative electrode should be disassembled first, and then the positive electrode. When installing, the order of connection of the positive and negative electrodes is reversed from that when dismantling.

### Note:

When charging a maintenance-free battery, read the instructions on the battery.

## Lamplight

The high beam of the vehicle is adjustable, and the light is adjusted by rotating the light adjustment knob.

### warning

Low and high beams are adjusted in accordance with local regulations, based on the light when the front and rear wheels are on the ground and the driver is seated in the car. The entire car is LED and needs to be replaced in its entirety if damaged.

## Fuse

Fuse Box 1 is set under the pedal and can be seen by removing the cap. If the fuse blows, check the electrical system for damage, and replace it with a new identical fuse.

### warning

No wire can be used to replace the corresponding fuse, replace it with a new fuse of the same amp. The corresponding amperage is marked on the fuse.

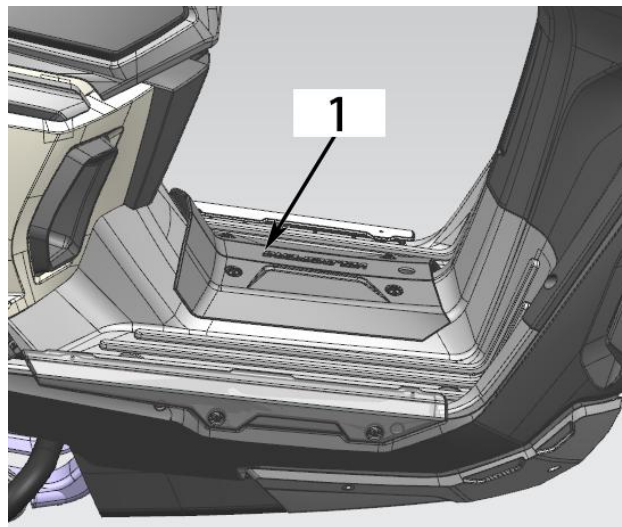

## catalytic converters

A catalytic converter is installed in the exhaust system. The platinum and rhodium inside the catalytic converter react with carbon monoxide and convert hydrocarbons into carbon dioxide and water for release into the atmosphere.

In order to use the catalytic converter correctly, the following warnings must be observed: Unleaded gasoline is recommended and leaded gasoline is prohibited. Leaded gasoline can severely shorten the life of the catalytic converter.

Do not let the vehicle slide with the ignition switch off or the shutdown switch , do not try to start the engine for a long time if the battery is running low, do not drag the car or allow the piston to move when the engine is not in neutral , under these conditions , too much unburned air-gas mixture will flow out of the engine and into the exhaust system , causing it to accelerate its reaction with the catalytic converter and cause damage when the engine warms up , or reduce catalytic converter performance when the engine is cold.



warning

use only unleaded gasoline, and even a small amount of lead can contaminate the precious metals in your catalytic converter and render it ineffective. Do not add anti-rust oil or engine oil to the muffler, otherwise the catalytic reaction conversion will fail.

## Fuel evaporation system

When the fuel evaporation system fails, contact the velocifero service shop for repair. Do not alter the fuel evaporation system, as this may result in non-compliance with fuel evaporative emission regulations. After disassembly and maintenance, check that the connection of each pipeline should be good, that there is no air leakage or blockage in the pipeline joint, and that the hose should not be extruded, cracked, damaged, etc. The fuel vapor in the fuel tank is released to the carbon tank by the desorption pipe, and when the engine stops working, the fuel vapor is absorbed by the activated carbon in the carbon canister; when the engine works, the fuel vapor in the carbon tank is released to the engine combustion chamber by the desorption pipe to participate in combustion, prevents the fuel vapor from being directly discharged into the atmosphere and causes environmental pollution. At the same time, the adsorption pipe also has the air pressure in the balance fuel tank, when the air pressure in the fuel tank is lower than the outside large air pressure, the air pressure in the fuel tank can be supplemented by the air pipe of the carbon tank and the adsorption pipe.

## Lubricating Oil Inspection and Replacement

**Oil Level Check** Check the lubricant level every day before driving.

1. Move the motor to the support position and place it on level ground with the main bracket.
2. After a few seconds, remove the dipstick, clean it and reinsert it without screwing it on. The oil must be between the upper and lower limit marks of the dipstick.
3. If desired, add the recommended oil up to the upper limit of the dipstick, but do not overfill.
4. Reinstall the dipstick. Please check for oil leaks. NOTE: The engine runs when the oil is low, which may cause damage to parts.
5. Change lubricating oil

Drain the oil while the engine is still warm. The drain plug is located under the engine fan. Place an empty oil drain container at the bottom of the engine, then unscrew the oil screw cap. Replace the drain plug and tighten it. ✕ Oil injection for 15W/40-SF grade gasoline engines is about 0.8 liters. Start the engine for about a few minutes before switching it off and check the oil level again and refuel if necessary. Note: Increase the number of oil changes based on dust contamination. Used lubricating oil cannot be disposed of at will and must be handed over to the local department with qualifications for recycling waste materials for unified recycling.

## REPLACEMENT OF COOLANT

1. The function of coolant Water-cooled motion coolant has the functions of low freezing, high boiling point, anti-corrosion, etc., its freezing point is  $-40^{\circ}\text{C}$ , and the boiling point is  $108^{\circ}\text{C}$  (1 standard atmosphere), which can prevent the engine from overheating

caused by idling or low-speed running, and can also prevent the formation of harmful substances in the radiator. Note: (1) The special coolant for water-cooled motorcycles is a coolant with a concentration of 55% that has been configured, which can be used directly, without reconfiguration, and it is forbidden to add water when the quantity is insufficient; (2) Cannot be mixed with other types of refrigerants; (3) This refrigerant is toxic and absolutely inedible.

2. Replacing the coolant Place the motorcycle on level ground and support the main bracket. After the engine has cooled down, place the tool under the drain under the water tank, pull out the water hose, wait for the coolant to drain out, then install the water hose and top up the coolant.

## How to drive the car



### Dangerous

check the status of the vehicle before each vehicle drive.

The vehicle must be driven with the appropriate driver's license.

Be aware of the local regulations and not drive in areas where you are not allowed.

The vehicle must not be started in an enclosed area or with an imperfect exhaust system, as the exhaust fumes generated during engine operation may cause loss of consciousness or death.

## start the vehicle

put away the side support and sit on the vehicle; Turn on the electric door lock switch.

press and hold the brake handle press and hold the “” button.



### warning

The engine running at high speeds at low temperatures can have a negative impact on the durability of the engine, and it is always necessary to warm up the engine at low speeds. Before the completion of the self-test of the instrument cluster, the start-out switch shall not be used to start the vehicle.

The vehicle is equipped with a side support switch, which needs to be retracted before the vehicle can be started.

Do not press the start stop switch for more than five seconds continuously, and wait at least 15 seconds before trying again, otherwise it will cause the battery to lose power.

The vehicle starts

carefully turn the throttle grip.

shift, drive

Hold the handlebars tightly and continue to drive.



warning

Avoid sudden changes to the load and strong braking maneuvers, which can cause the vehicle to lose control.

Adjust your speed according to road conditions and surrounding conditions. All adjustments to the vehicle should be carried out at the time of parking.

Ensure that the passenger is seated in the passenger seat as specified, with their feet on the rear pedals, wearing safety protection such as helmets, and holding the driver or grasping the armrest.

Please comply with the minimum age regulations for passengers in your country or region.

Please obey traffic rules and drive precautionarily and cautiously to identify hazards as early as possible.

When the tires are in a cold condition, grip is reduced, and you must drive carefully at a moderate speed for the first few kilometers until the tires reach their operating temperature.

Do not exceed the maximum allowable total load, which includes: a ready, fully fueled vehicle, driver, passengers, and carry-on baggage.

## Brake

When braking, the throttle should be released and the front and rear brakes should be used at the same time.

The braking process should be completed before starting a turn.



warning

Moisture and dirt can affect the braking system, and when the brake disc is wet, brake carefully several times to dry the brake pads and disc and remove dust.

If the brake handle feels soft, it cannot continue to drive, and it must be troubles before use .

when braking is not required, remove the foot from the brake pedal, prolonged use of the brake will cause the brake pad to overheat, excessive wear, affect the service life and safety.

when carrying passengers or luggage, the braking distance may increase, please adjust the braking time according to the vehicle load.

with CBS, full braking force can be used for full braking and in conditions of low adhesion on sandy, waterlogged or slippery surfaces, without the danger of wheel locking.

park

use the brakes to stop the vehicle.

Turn off the ignition.

park the vehicle on solid, level ground.

use side braces or middle braces (if equipped) to carry the vehicle.

Turn the steering knob to the left and lock the directional lock with the key.

Remove and save the key.



warning

When the engine is running, someone must take care of the vehicle. prevent unauthorized operation of the vehicle.

Lock the directional lock when exiting the vehicle.

some parts of the vehicle are very hot after operation, please be careful to touch the exhaust system, cooling system, braking system and engine.

Do not place the vehicle near flammable or explosive materials, as hot vehicle parts may ignite or detonate the material.

Improper handling while parking can cause the vehicle to slide or tip over, resulting in serious injury.

The center support is only used to carry the vehicle and luggage, please do not sit on the vehicle when using the center support to dock, otherwise the center support or frame may be damaged, and the vehicle may tip over.

## Drive safely

### safe driving tips

The following are the daily driving precautions, which must be read carefully before driving to ensure safe and correct driving.

For safety, it is strongly recommended to wear goggles and helmets, you must be aware of the traffic laws for driving a motorcycle safely, and you must also wear gloves and appropriate protective gear such as shoes and Socks.

To prevent collisions with vehicles, you must wear protective clothing while driving, and your personal safety will not be guaranteed without wearing protective clothing. Look for your left, right and rear vehicles before changing lanes to make sure it's safe to pass. Don't just rely on the mirror, you have to judge the distance and speed of other vehicles, otherwise you are prone to car accidents.

When braking is used, the front and rear brakes are used at the same time. If only one is used, sudden braking can cause the vehicle to slide (slide) and lose control.

When descending on long slopes, release the throttle to control speed, and use front and rear auxiliary braking.

When driving in wet terrain, try to use the throttle to control the speed, reduce the braking force of the front and rear wheels, and the throttle must also be properly controlled, so as to avoid letting the rear wheels accelerate too fast or decelerate too fast to cause the vehicle to slip.

Driving at a smooth speed and avoiding unnecessary acceleration not only ensures important personal safety, but also reduces fuel consumption, extends the life of the vehicle and reduces noise.

When driving on wet or soft roads, it will reduce the maneuverability of the motorcycle. Under these conditions, your entire driving maneuver must be coordinated and agile, and sudden acceleration, braking, or turning can cause a loss of control.

practice driving cautiously in open areas, slowing down and maintaining vehicle stability  
Avoid unnecessary braid entangled in the driver and vehicle.

### Daily security checks

check the following items before driving every day. Developing this habit can ensure the safety of your driving and the reliability of the vehicle. If any abnormality is found, please read the adjustment chapter or contact your dealer for repair. if you find any abnormality and continue to drive, it may cause serious damage to the vehicle or cause an accident.

project	content
Front wheel	Inspect the front wheel for excessive wear, cuts, inserted foreign bodies, or other damage.
Front brakes	check the thickness of the front brake pads.
Engine oil	check the thickness of the brake disc and the fouling.

Rear brake oil Cup

check if the oil level is appropriate.

project	content
Rear wheels	check whether the rear brake oil cup fluid level is appropriate. Inspect the rear wheel for excessive wear, cuts, inserted foreign bodies, or other damage.
Rear brake	check the thickness of the rear brake pads. check the thickness of the brake disc and the fouling.
Front brake oil Cup	check whether the liquid level of the front brake oil Cup is appropriate.
appearance	check the instrument fault display. check if the fuel reserves are sufficient
Rear view mirrors	check that all luminaires are lit proper luminaires meet the requirements of y and that the light height of the front local regulations.
Lamps	check that the steering handlebars, front and rear brakes, throttle, and switches are working properly and flexibly.
operating elements	check whether the support return spring in the side brace is loose or broken.
side brace middle brace	check whether the support return spring in the side brace is loose or broken.
kill switch	check if the flame out switch can be used normally.

### special precautions for high-speed driving

**Braking:** Braking is very important when driving at high speeds, and the braking force cannot be too large. check and make appropriate adjustments to ensure proper braking performance.

**Manipulation:** The vehicle will lose control if the operating parts are lost. check that the handlebar should be flexible but not wobbly.

**Tires:** Tires should be firm when driving at high speeds and keeping tires in good condition is key to safe driving. check the air pressure thoroughly, and the rotation is smooth. **Fuel:** Ensure sufficient fuel and smooth fuel supply when driving at high speeds.

**Engine oil:** To avoid engine failure and loss of control, make sure that the oil level is above the dipstick, between the lower limit scale marks, and as far as possible in the middle.

**Electrical installations:** Make sure all headlights, taillights/brake lights, turn signals, horns, etc. are working properly.

**Fasteners:** Make sure all nuts and bolts are fastened and that all safety-related components are intact.



**Dangerous**

Please do not exceed the speed limit on the highway and follow the relevant laws and regulations, unless you have the permission of the traffic control department, and have the relevant skills and protective conditions.

## Break-in period

The run-in period of this car is the first time to drive 1000 km, and regular maintenance work is done according to the provisions of the run-in period.

The following regulations must be complied with during the run-in period:

1. Do not press the start button during driving and do not run the engine at high speed immediately after starting, even after the engine is warmed up, you should first run in the idle state (2 ~ 3) minutes, so that the lubricating oil can enter each lubricating part of the engine.
2. Don't let the engine speed go too high.
3. The maximum engine speed we recommend during the break-in period is as follows

The total mileage traveled by the vehicle	Maximum starting speed
0 km ~ 500 km	4000 r/min
500 km ~ 1 000 km	6000 r/min



**Dangerous**

The new tire tread is smoother and can cause loss of control and injury. The specified tire pressure must be guaranteed during the 1000 km break-in period. During the run-in period, avoid sudden braking or excessive braking force, sudden acceleration or sharp turns.

## service intervals

This chapter lists the maintenance charts, and in order to keep the vehicle in good condition, it is necessary to comply with the provisions of the maintenance charts and do a good job of regular maintenance and adjustment. The first service is also extremely important and should not be neglected.

With a lot of coverage in this chapter, you should be aware of the basic maintenance procedures and the proper use of tools. If you lack practical experience or are skeptical about your ability, all adjustments, maintenance and repairs must be carried out by a professional technician. If you have any further questions, please contact your dealer.

## precautions

▲ = 50% reduction in vehicle maintenance intervals when the vehicle is subjected to severe use.

■ = Have an authorized dealer repair the part or system in question.

Maintenance table during the break-in period.

project		Maintenance intervals during the break-in period (Maintenance of items with first-come, first-served)			
		Hour	Month	km	Remarks
<b>Motor</b>					
■	Oil and oil filters			1000	Replacement
■	Oil coarse strainer			1000	clean
	Idle speed			1000	examine electric
	Valve clearance			1000	
	Throttle system			1000	
<b>Electric</b>					
■	Functions of electrical equipment			1000	brake
	Accumulator			1000	
	Fuses or overload protectors			1000	
<b>Brake</b>					
	Brake discs			1000	clean
	Brake pads			1000	
	Brake fluid level			1000	
■	Brake lines			1000	check if there is any damage, whether it is sealed

$\Delta$  = 50% reduction in vehicle maintenance intervals when the vehicle is subjected to severe use.

■ = Have an authorized dealer repair the part or system in question.

project		Maintenance intervals during the break-in period (Maintenance of items with first-come, first-served)			
		Hour	Month	km	Remarks
<b>Wheels</b>					
	Tire condition			1000	examine
	Tire pressure			1000	
<b>suspension</b>					
■	Rear and front shocks			1000	check for oil leaks. (Press.) As needed and for the purpose of use Fork and rear shock absorber for maintenance)
<b>Steering parts</b>					
■	Steering bearings			1000	examine

$\Delta$  = 50% reduction in vehicle maintenance intervals when the vehicle is subjected to severe use.

■ = Have an authorized dealer repair the part or system in question.

project		Maintenance intervals during the break-in period (Maintenance of items with first-come, first-served)			
		Hour	Month	km	Remarks
other					
■	Fault memory			1000	Read using the diagnostic tool
■	All moving parts			1000	lubrication, check its flexibility
■	Bolts and nuts			1000	check that it is secure
■	cable			1000	check for damage, bending and its setting

▲ = 50% reduction in vehicle maintenance intervals when the vehicle is subjected to severe use.

■ = Have an authorized dealer repair the part or system in question.

Maintenance table after the break-in period

project		Maintenance intervals during the break-in period (Maintenance of items with first-come, first-served)			
		Hour	Month	km	Remarks
Motor					
	Oil and oil filters		6M	5000	replacement
	Oil coarse strainer		6M	5000	clean
	Idle speed			10000	
	Throttle system			5000	examine
▲	Air filter cartridges			5000	clean
■		24M	20000	replacement	
■	spark plug			2000	examine
				6000	examine
■	valve clearance			200	examine

▲ = 50% reduction in vehicle maintenance intervals when the vehicle is subjected to severe use.

■ = Have an authorized dealer repair the part or system in question.

project		Maintenance intervals during the break-in period (Maintenance of items with first-come, first-served)			
		Hour	Month	km	Remarks
Electric					
■	Electrical equipment features		12M	10000	examine
	accumulator		6M	5000	
	Fuses or overload protectors		6M	5000	
■	cable		12M	10000	check for damage, bending during laying.
wheels					
	Tire condition		12M	7500	examine
		24M	15000		
	Tire pressure		12M	7500	
		24M	15000		

■	wheel bearings	7500	
---	----------------	------	--

project		Maintenance intervals during the break-in period (Maintenance of items with first-come, first-served)			
		Hour	Month	km	Remarks
Brake					
	Front and rear braking systems		12M	7500	examine
			24M	15000	
	Brake discs		12M	7500	
			24M	15000	
▲	Brake pads		12M	7500	
			24M	15000	
	Brake fluid level		12M	7500	
			24M	15000	
■	Brake lines		12M	7500	check for damage, whether it is sealed or not
			24M	15000	
■	Brake fluid		24M		replacement

▲ = 50% reduction in vehicle maintenance intervals when the vehicle is subjected to severe use.

■ = Have an authorized dealer repair the part or system in question.

project		Maintenance intervals during the break-in period (Maintenance of items with first-come, first-served)			
		Hour	Month	km	Remarks
Suspension					
■	Fault memory		12M	7500	Read using the diagnostic tool.
			24M	15000	
■	All moving parts		12M	7500	lubrication, check its flexibility
			24M	15000	
■	Bolts and nuts		12M	7500	check if it's secure.
			24M	15000	
■	cable		12M	7500	check for damage, bending and its setting
			24M	15000	
■	All hoses and sleeves		12M	7500	check for cracks , yes whether it is sealed and whether it is correctly arranged.
			24M	15000	

▲ = 50% reduction in vehicle maintenance intervals when the vehicle is subjected to severe use.

■ = Have an authorized dealer repair the part or system in question.

## COMMON FAULTS AND CAUSES OF MOTORCYCLES

phenomenon	place	cause	Dispose
cannot be started	Fuel system	There is no fuel in the tank	Add fuel
		Blocked or damaged fuel pumps, poor fuel quality	wash or replace
	ignition system	spark plug failure, carbon deposit, long service time	inspection or replacement
		Faulty spark plugs caps, poor contact or burnout	inspection or replacement
		ignition coil failure, poor contact or burning	inspection or replacement
		ECU malfunction, poor contact or burnout	inspection or replacement
		Trigger coil failure, poor contact or burnout	inspection or replacement
		stator failure, poor contact or burnout	inspection or replacement
		Faulty connecting lines, poor contact	check or adjust
	cylinder pressure system	Faulty starting mechanism, wear or damage	inspection or replacement
		Intake and exhaust valves, valve seats are faulty, the fuel contains a lot of gum or has been used for a long time	inspection or replacement
		cylinder, piston, piston ring failure, colloidal or abrasion of fuel	inspection or replacement
		Leakage of air intake pipe, too long of use	inspection or replacement
		valve timing failure	inspection or replacement

## COMMON FAULTS AND CAUSES OF MOTORCYCLES

phenomenon	place	cause	Dispose
Lack of power	valve pistons	Excessive carbon deposit in intake and exhaust valves and pistons, poor fuel quality, and poor oil quality	Repair or replacement
	cylinder block, ring	wear of cylinder block and piston rings, poor oil quality, and long service time	change the oil
	Brake	The brakes are not completely disengaged, and the brakes are too tight	adjust
	Motor	The engine is overheated, the mixture is too thick or too thin, the oil and fuel quality are poor, and there are shields	Adjust or replace
	spark plug	Improper sparks plug clearance: normal: 0.8mm ~ 0.9mm	Adjust or replace
	Air intake pipe	Leakage of air intake pipe, too long of use	Adjust or replace
	cylinder head	Cylinder head or valve leakage	Inspection or replacement
	Electrical systems	The electrical system is faulty	Inspection or replacement
	Air filter	The air filter is clogged	cleaning or adjustment
poor headlights and taillights	cable	poor line connection	adjust
	Left and right switches	poor or damaged switch contact	Adjust or replace
	Headlights	Faulty or damaged bulbs, lamp holders	Adjust or replace
	Regulator	Regulator inspection, poor contact or burning	Inspection or replacement
	Magneto	clicks on the coil to check, poor contact or burning	Inspection or replacement
The horn does not sound	Accumulator	The battery has no power	charge or replace
	Left switch	The horn button is faulty or damaged	Adjust or replace
	cable	poor line contact	Adjust or replace
	Horn	The horn is damaged	Adjust or replace

Listed above are the common faults of motorcycles. If your motorcycle is faulty (especially if the EFI System or fuel evaporation system fails), please contact the "velocimetry Repair station" in time for timely inspection and repair.



## Dangerous

You can't deal with motorcycle failures by yourself, otherwise it is easy to cause potential safety hazards or safety accidents. If the user deals with the motorcycle failure by himself, the user shall be responsible for the safety accident.

### VEHICLE CLEANING AND STORAGE General precautions

keeping your vehicle clean and driving at peak performance will extend the life of your vehicle. protect your vehicle with high-quality, breathable motorcycle covers.

Make sure the engine and exhaust pipe are cooled before cleaning.

- o Avoid using detergents on seals, brake pads, and tires.
- o Manual vehicle washing.
- o Avoid using chemicals, dissolving liquids, detergents, and household cleaners to clean your vehicle, such as ammonia.
- o Gasoline, brake fluid and coolant will damage the surface of the painted parts, if it sticks to the surface of the painted parts, it should be cleaned with water immediately.
- o Avoid using metal brushes, wire cleaning balls, or other items that are too rough to wipe the vehicle.
- o special care should be taken when washing the windshield, lampshade, and all plastic parts that are prone to scratches.
- o Avoid using high-pressure water cannons, otherwise water may flow into the seals and electrical components and damage your vehicle.
- o Avoid spraying water into waterproof areas such as air intakes, fuel systems, electrical components, muffler exhaust ports, and fuel tank locks.

### car wash

- o Rinse the dirt off the motorcycle with cold water.
- o Mix a moderate amount of detergent (a special detergent for washing motorcycles or cars) and clean water. use soft cloth or sponge to wash your vehicle. If needed, mix a bucket of light degreaser to clean the oil or grease dirt.
- o After washing, use clean water to rinse the residue from the car (cleaning agent residue may damage your motorcycle parts).
- o uses a soft cloth to dry your motorcycle and check your motorcycle for scratches.
- o starts the engine and let it work at idle for a few minutes, the heat generated by the engine helps to dry the vehicle in a humid environmental area.

o Drive your vehicle cautiously at low speeds and use the brakes a few times. This helps

to dry the brake and return it to normal operating performance. 36

## Note:

Just wash your vehicle with cold water immediately after driving on a road with high salt spray or near the sea. Do not use warm water that accelerates the chemical reaction of sodium chloride. After wiping dry, the surface of the metal non-coating is protected by anti-rust and corrosive oil. If you are driving on a rainy day or after a car wash, there may be water mist on the inner surface of the headlamp shade, start the engine and turn on the headlamp to remove the water vapor.

## Decorate the surface

After washing the car, the surface of the metal and plastic parts coated with wax for motorcycles or automobiles is varnished. wax must be applied every three months or if necessary to avoid satin or matte on the surface of the coating. Ensure that the wax used is a non-abrasive product and that it is handled according to its instructions. windshields and other plastic parts

After washing, use a soft cloth to gently dry the surface of the plastic parts. when drying, use the prescribed cleaning or glazing procedures for windshield glass, lampshades and other uncoated plastic parts.

### warning

Plastic parts can deteriorate and crack if they come into contact with chemically reactive substances or household cleaning products such as gasoline, brake fluid, window cleaning fluids, thread fasteners or other chemicals. If plastic parts come into contact with any reactive chemicals, wash them off immediately with water and check for damage. Avoid using abrasive sheets or brushes to clean the surface of plastic parts, as they will damage the surface gloss of plastic parts.

## chrome and aluminum

Both chrome alloys and uncoated aluminum parts are oxidized by the air, leaving the surface dull and dull, and must be cleaned with a detergent and varnished with a polish. Both coated and unpainted aluminum wheels must be cleaned with a special detergent. Leather products, vinyl products and rubber products

If your motorcycle has leather goods, you must use a leather cleaner. washing leather goods with detergent and water will damage them and shorten their lifespan.

The surface of vinyl products must be treated separately when washing the car.

Tires and other rubber parts must be protected by special rubber protectants to extend their service life.

### Dangerous

When handling tires, special care must be taken to understand that the rubber protectant applied to the tire does not affect the function of the tire. Improper handling may affect the adhesion of the tire to the ground and cause the driver to lose control.

preparation before storage

clean the whole vehicle thoroughly.

Allow the engine to work for about 5 minutes, stop the engine from working, and drain the oil inside the engine.



Dangerous

oil on motorcycles is toxic and used oil should be disposed of thoroughly. keep it out of the reach of small children. If it sticks to your skin, treat it accordingly immediately.

change to new engine oil. Add fuel, add fuel additives.



Dangerous

Gasoline is very susceptible to combustion and explosion under certain conditions, so it is necessary to set the power key in the "OFF" position before operating it, no smoking, make sure that the area is well ventilated, no flames or electric sparks, and also include the work lights used. Gasoline is a toxic substance and should be disposed of properly, disposed of immediately if it comes into contact with your skin, and stored out of reach of children.

During the storage of the motorcycle, the standard air pressure of the tires is reduced by approximately 20%.

use planks to hold the front and rear wheels firmly to prevent the motorcycle from touching the ground and getting wet.

spray an oil film on uncoated metal surfaces to prevent rust and avoid spraying oil onto rubber parts or brakes.

Lubricate all cables.

Remove the battery and store it in a cool, ventilated place. During storage, the battery must be charged according to the provisions of the regular maintenance chart to keep the battery sufficient.

The muffler exhaust port is wrapped in a plastic bag to prevent moisture from entering. cover with a motorcycle cover to protect against dust.

Remove the vehicle from storage

Remove the plastic bag from the muffler exhaust port.

Install the battery and charge it first if necessary.

Review routine security checks.

lubrication of pivots; Take a test drive.

Taizhou velocifero vehicle Co., Ltd.

509 Tengyun Road, Jiaojiang District, Taizhou, Zhejiang. province, China

TEL: +86-576-89203009

E-mail: [info@velocifero.com.cn](mailto:info@velocifero.com.cn)

website: [www.velocifero.eu](http://www.velocifero.eu)

# VELOCIFERO

# MOBSTER

Taizhou Velocifero Co.,Ltd./ Mai way Industry Co., Ltd.

Add: No.509,Tengyun Road,Jiaojiang District,  
Taizhou City,Zhejiang Province,China

Facebook:Velocifero

Web:www.velocifero.eu

Email:info@velocifero.com.cn

info@mai-way.com



VELOCIFERO.EU